

# Rosemount 1151 Pressure Transmitter

- *Proven field performance and reliability*
- *Commitment to continuous improvement*
- *Reference accuracy of 0.075%*
- *Two-year stability of 0.1%*
- *Rangeability of 50:1*

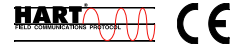

## Contents

Specifications . . . . .	page 3
Product Certifications . . . . .	page 8
Dimensional Drawings . . . . .	page 10
Ordering Information . . . . .	page 16

## Leading a tradition of excellence

With over five million transmitters installed worldwide, the Rosemount 1151 continues to offer industry leading value. Changing customer needs and new technologies have driven product improvements, while advanced manufacturing and testing processes have guaranteed product quality. Even today, the Rosemount 1151 is world-reowned for proven field reliability and longevity.

### Proven field performance and reliability

For over 35 years, the 1151 has provided the process control industry with unsurpassed service and reliability in even the harshest of environments. The lasting customer preference results from a combination of advanced technology, and a tradition of field proven performance.

### Commitment to continuous improvement

Through ongoing focus on continuous improvement,  $\pm 0.075\%$  reference accuracy has been accomplished as a result of manufacturing and engineering enhancements. In addition, Smart electronics offer rangeability to 50:1, reducing the number of transmitters to specify, procure, and carry in inventory. A modular design allows interchangeable mechanical and electrical components, providing backward and forward compatibility.

### Application flexibility

The 1151 offers a variety of configurations for differential, gage, absolute and liquid- level measurements including integrated solutions for pressure, level, and flow. High pressure models allow static line pressures up to 4500 psi (310 bar). Multiple wetted materials, as well as alternative fill fluids ensure process compatibility. Smart, analog and low-power electronics are available to meet specific application requirements.

## Rosemount Pressure Solutions

### Rosemount 3051S Series of Instrumentation

Scalable pressure, flow and level measurement solutions improve installation and maintenance practices.

### Rosemount 3095 Mass Flow Transmitter

Accurately measures differential pressure, static pressure and process temperature to dynamically calculate fully compensated mass flow.

### Rosemount 305, 306 and 304 Manifolds

Factory-assembled, calibrated and seal-tested transmitter-to-manifold assemblies reduce installation costs.

### Rosemount 1199 Diaphragm Seals

Provides reliable, remote measurements of process pressure and protects the transmitter from hot, corrosive, or viscous fluids.

### Orifice Plate Primary Element Systems: Rosemount 1495 and 1595 Orifice Plates, 1496 Flange Unions and 1497 Meter Sections

A comprehensive offering of orifice plates, flange unions and meter sections that are easy to specify and order. The 1595 Conditioning Orifice provides superior performance in tight fit applications.

### *Annubar*<sup>®</sup> Flowmeter Series: Rosemount 3051SFA *ProBar*<sup>®</sup>, 3095MFA Mass *ProBar*<sup>®</sup>, and 485

The state-of-the-art, fifth generation Rosemount 485 *Annubar* combined with the 3051S or 3095 *MultiVariable* transmitter creates an accurate, repeatable and dependable insertion-type flowmeter.

### Compact Orifice Flowmeter Series: Rosemount 3051SFC, 3095MFC, and 405

Compact Orifice Flowmeters can be installed between existing flanges, up to a Class 600 (PN100) rating. In tight fit applications, a conditioning orifice plate version is available, requiring only two diameters of straight run upstream and two downstream.

### *ProPlate*<sup>®</sup> Flowmeter Series: Rosemount 3051SFP *ProPlate*, 3095MFP Mass *ProPlate*, and 1195

These integral orifice flowmeters eliminate the inaccuracies that become more pronounced in small orifice line installations. The completely assembled, ready to install flowmeters reduce cost and simplify installation.

## Specifications

### PERFORMANCE SPECIFICATIONS

(Zero-based calibrated ranges, reference conditions, silicone oil fill, 316 SST isolating diaphragms.)

#### Accuracy

Output Code S

Ranges 3 through 8, DP and GP transmitters;  
Ranges 4 through 7, HP transmitters  
 $\pm 0.075\%$  of calibrated span for spans from 1:1 to 10:1 of URL.  
Between 10:1 and 50:1 of URL.

$$\text{accuracy} = \pm \left[ 0.02 \left( \frac{\text{URL}}{\text{span}} \right) - 0.1 \right] \% \text{ of calibrated span}$$

All other ranges and transmitters

$\pm 0.25\%$  of calibrated span<sup>(1)</sup>

Output Code S, square root mode

$$\pm \left[ 0.2 + 0.05 \times \left( \frac{\text{URL}}{\text{span}} \right) \right] \% \text{ of calibrated flow span}$$

Output Codes E, G, L, and M

$\pm 0.2\%$  of calibrated span for 1151DP Ranges 3 through 5. All other ranges and transmitters,  $\pm 0.25\%$  of calibrated span.

#### Stability

Output Code S

$\pm 0.1\%$  of URL for 2 years for DP and GP Ranges 3 through 8. ( $\pm 0.25\%$  for all other ranges and transmitters.)

Output Codes E and G

$\pm 0.2\%$  of URL for six months for Ranges 3 through 5. ( $\pm 0.25\%$  for all other ranges.)

Output Codes L and M

$\pm 0.25\%$  of URL for six months

#### Temperature Effect

Output Code S [–20 to 185 °F (–29 to 85 °C)]

For DP and GP transmitter Range 4 through 8;  
HP transmitter Range 4 through 7:

Zero Error =  $\pm 0.2\%$  URL per 100 °F (56 °C)  
Total Error =  $\pm(0.2\%$  URL + 0.18% of calibrated span) per 100 °F; For Range 3, double the stated effects. For other ranges and transmitters follow analog temperature specifications (Output Code E).

Output Code E, G, L, and M

[–20 to 200 °F (–29 to 93 °C)]  
For Ranges 4 through 0

Zero Error =  $\pm 0.5\%$  URL per 100 °F.  
Total Error =  $\pm(0.5\%$  URL + 0.5% of calibrated span) per 100 °F; double the effect for Range 3.

#### Static Pressure Effect – DP Transmitters

*DP Transmitters*

Zero Error

$\pm 0.25\%$  of URL for 2,000 psi (13790 kPa)  
for Range 4 and 5 or  $\pm 0.5\%$  for other ranges, correctable through rezeroing at line pressure.

Span Error

Correctable to  $\pm 0.25\%$  of input reading per 1,000 psi (6895 kPa), or to  $\pm 0.5\%$  for Range 3.

*HP Transmitters*

Zero Error

$\pm 2.0\%$  of URL for 4,500 psi (31027 kPa), correctable through rezeroing at line pressure.

Span Error

Correctable to  $\pm 0.25\%$  of input reading per 1,000 psi (6895 kPa).

#### Vibration Effect

0.05% of URL per g to 200 Hz in any axis

#### Power Supply Effect

Output Codes S, E, and G

Less than 0.005% of output span per volt

Output Codes L, M

Output shift of less than 0.05% of URL for a 1 V power supply shift

#### Load Effect

Output Codes S, E, and G

No load effect other than the change in power supplied to the transmitter.

Output Codes L, M

Less than 0.05% of URL effect for a change in load from 100k $\Omega$  to infinite ohms.

#### Short Circuit Condition (Low Power Only)

No damage to the transmitter will result when the output is shorted to common or to power supply positive (limit 12 V).

#### EMI/RFI Effect

Output shift of less than 0.1% of span when tested to SAMA PMC 33.1 from 20 to 1000 MHz and for field strengths up to 30 V/m.

(1) Accuracy for Range 9, GP transmitter at 40:1 is  $\pm 0.7\%$  of calibrated span.

## Mounting Position Effect

Zero shift of up to 1 inH<sub>2</sub>O (0.25 kPa).

With liquid level diaphragm in vertical plane, zero shift of up to 1 inH<sub>2</sub>O (0.25 kPa). With liquid level diaphragm in horizontal plane, zero shift of up to 5 inH<sub>2</sub>O (1.25 kPa) plus extension length on extended units. All zero shifts can be calibrated out. No effect on span.

## FUNCTIONAL SPECIFICATIONS

### Service

Liquid, gas, and vapor applications

### Ranges

See Table 2 for ranges. Minimum span equals the upper range limit (URL) divided by rangedown. Rangedown varies with the output code See Table 1.

### Outputs

Code S, Smart

4–20 mA dc, user selectable for linear or square root output. Digital process variable superimposed on 4–20 mA signal, available to any host that conforms to the HART<sup>®</sup> protocol.

Code E, Analog

4–20 mA dc, linear with process pressure

Code G, Analog

10–50 mA dc, linear with process pressure

Code L, Low Power

0.8 to 3.2 V dc, linear with process pressure

Code M, Low Power

1 to 5 V dc, linear with process pressure

### Current Consumption Under Normal Operating Conditions (Low Power Only)

Output Code L

1.5 mA dc

Output Code M

2.0 mA dc

### Zero Elevation and Suppression

Output Codes S, E, and G

Zero elevation and suppression must be such that the lower range value is greater than or equal to the (–URL) and the upper range value is less than or equal to the (+URL). The calibrated span must be greater than or equal to the minimum span and less than or equal to the maximum span.

Output Code L

Zero is adjustable ±10% of URL and span is adjustable from 90 to 100% of URL.

Output Code M

Zero is adjustable ±50% of URL and span is adjustable from 50 to 100% of URL.

### Span and Zero

Output Code S

Span and zero may be accessed with local adjustments or remotely through a HART-compatible Interface.

Output Codes E, G, L, and M

Span and zero are continuously adjustable.

### Power Supply

External power supply required. Transmitter operates according to the following requirements:

Output Codes S, E

12 to 45 V dc with no load

Output Code G

30 to 85 V dc with no load

Output Code L

5 to 12 V dc

Output Code M

8 to 14 V dc

Where:

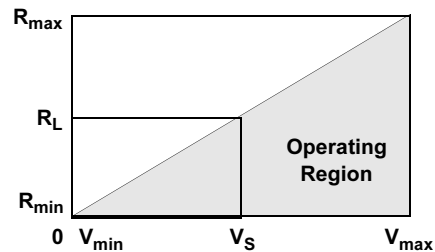

Code	V <sub>min</sub>	V <sub>max</sub>	R <sub>min</sub>	R <sub>max</sub>	R <sub>L</sub> at Supply Voltage (V <sub>S</sub> )
S <sup>(1)</sup>	12	45	0	1650	R <sub>L</sub> = 43.5 (V <sub>S</sub> – 12)
E <sup>(2)</sup>	12	45	0	1650	R <sub>L</sub> = 50 (V <sub>S</sub> – 12)
G	30	85	0	1100	R <sub>L</sub> = 20 (V <sub>S</sub> – 30)
L	5	12	Low Power Minimum Load Impedance: 100 kΩ		
M	8	14			

(1) A minimum of 250 ohms is required for communication.

(2) For CSA approvals V<sub>max</sub> = 42.4 V dc.

### Temperature Limits

Electronics Operating

Code S: –40 to 185 °F (–40 to 85 °C)

Code E: –40 to 200 °F (–40 to 93 °C)

Code G, L, M: –20 to 200 °F (–29 to 93 °C)

Sensing Element Operating

Silicone fill: –40 to 220 °F (–40 to 104 °C)

Inert fill: 0 to 160 °F (–18 to 71 °C)

Storage

Code S: –60 to 185 °F (–51 to 85 °C)

Codes E, G, L, M: –60 to 250 °F (–51 to 121 °C)

# Product Data Sheet

00813-0100-4360, Rev HA

March 2008

# Rosemount 1151

TABLE 1. Rangeability

Output Code	Minimum Span	Maximum Span
S (DP and GP, SST, Range 3–8; HP SST, Range 4–7)	URL/50	2 × URL <sup>(1)</sup>
S (All Others)	URL/50 <sup>(2)</sup>	2 × URL <sup>(1)</sup>
E, G	URL/6	URL
L	URL/1.1	URL
M	URL/2	URL

(1) Transmitter is capable of measuring from –URL to URL.

(2) Accuracy specification for calibrated spans from 1:1 to 6:1 of URL only.

TABLE 2. Transmitter Range Availability by Model (URL = Upper Range Limit)

Range Code	1151 Ranges (URL)	DP	HP	GP	DP/GP/Seals	AP	LT
3	30 inH <sub>2</sub> O (7.46 kPa)	•	NA	•	NA	NA	NA
4	150 inH <sub>2</sub> O (37.3 kPa)	•	•	•	•	•	•
5	750 inH <sub>2</sub> O (186.4 kPa)	•	•	•	•	•	•
6	100 psi (689.5 kPa)	•	•	•	•	•	•
7	300 psi (2,068 kPa)	•	•	•	•	•	NA
8	1,000 psi (6,895 kPa)	•	NA	•	NA	•	NA
9	3,000 psi (20,684 kPa)	NA	NA	•	NA	NA	NA
0	6,000 psi (41,369 kPa)	NA	NA	•	NA	NA	NA

TABLE 3. Upper Range Limits (URL)

Range Code	bar	mbar	kg/cm <sup>2</sup>	psi	kPa	inH <sub>2</sub> O @20 °C	mmH <sub>2</sub> O @20 °C	inHg @0 °C
3	0.075	75	0.076	1.082	7.461	30	762	2.203
4	0.373	373	0.380	5.409	37.305	150	3810	11.013
5	1.865	1865	1.901	27.045	186.505	750	19050	55.065
6	6.90	6895	7.031	100	690	2773	70434	204
7	21	20685	21	300	2069	8319	211302	611
8	69	68950	70	1000	6895	27730	704340	2036
9	207	206850	211	3000	20685	83190	2113020	6108
0	413.686	413686	421.842	6000	41369	166378	4225992	12216.12

TABLE 4. Output Code Availability

Code	1151 Output Options/Damping	DP	HP	GP	DP/GP/Seals	AP	LT
S	4–20 mA, Digital, Smart/Variable	•	•	•	•	•	•
E	4–20 mA, Linear, Analog/Variable	•	•	•	•	•	•
G	10–50 mA, Linear, Analog/Variable	•	•	•	•	•	•
L	0.8 to 3.2 V, Linear, Low Power/Fixed	•	•	•	•	•	NA
M	1 to 5 V, Linear, Low Power/Fixed	•	•	•	•	•	NA

TABLE 5. Fill Fluid Specifications

Fill Fluid	Temperature Limits <sup>(1)</sup>	Specific Gravity	Coeff. of Therm. Exp. cc/cc/°F (cc/cc/°C)	Viscosity at 25 °C centistokes
D.C. <sup>®</sup> 200 Silicone	–40 to 400 °F (–40 to 205 °C)	0.934	0.00060 (0.00108)	9.5
D.C. 704 Silicone	60 to 400 °F (15 to 204 °C)	1.07	0.00053 (0.00095)	44
Inert Fill	–50 to 350 °F (–45 to 177 °C)	1.85	0.0004 (0.000864)	6.5
Syltherm <sup>®</sup> XLT, Silicone	–100 to 300 °F (–73 to 149 °C)	0.85	0.000666 (0.001199)	1.6
Glycerin and Water <sup>(2)</sup>	0 to 200 °F (–17 to 93 °C)	1.13	0.00019 (0.00034)	12.5
Propylene Glycol and Water <sup>(3)</sup>	0 to 200 °F (–17 to 93 °C)	1.02	0.00019 (0.00034)	2.85
Neobee M-20 <sup>®(3)</sup>	0 to 400 °F (–17 to 205 °C)	0.900	0.00056 (0.001008)	9.8

(1) Temperature limits are reduced in vacuum service. Contact an Emerson Process Management representative for assistance.

(2) Glycerin and Water and Propylene Glycol and Water are not suitable for vacuum service.

(3) Not compatible with Buna-N or Ethylene-Propylene O-ring material.

# Rosemount 1151

## Static Pressure and Overpressure Limits

### 1151DP

0 psia to 2,000 psig (0 to 13.79 MPa) on either side without damage to transmitter. Operates within specifications from static line pressures of 0.5 psia (3.45 kPa) to 2,000 psig (13.79 MPa).

### 1151HP

0 psia to 4,500 psig (0 to 31.02 MPa) on either side without damage to transmitter. Operates within specifications from 0.5 psia (3.45 kPa) to 4,500 psig (31.02 MPa). Consult an Emerson Process Management representative for higher Static Pressure options up to 6000 psi.

### 1151AP

0 psia to 2,000 psia (0 to 13.79 MPa) without damage to transmitter. Operates within specifications from 0 psia to the upper range limit of the transmitter.

### 1151GP

0 psia to 2,000 psig (0 to 13.79 MPa) for ranges to 1,000 psig (6.90 MPa), 4,500 psig (31.02 MPa) for the 3,000 psig (20.68 MPa) range, and 7,500 psig (51.71 MPa) for the 6,000 psig (41.37 MPa) range, without damage to the transmitter. Operates within specifications from 0.5 psia (3.45 kPa) to the upper range limit of the transmitter.

### 1151LT

TABLE 6. Flange Pressure Rating

Standard	Class/Rating	Carbon Steel	Stainless Steel
ANSI	150	285 psig <sup>(1)</sup>	275 psig <sup>(1)</sup>
ANSI	300	740 psig <sup>(1)</sup>	720 psig <sup>(1)</sup>
ANSI	600	1,480 psig <sup>(1)</sup>	1,440 psig <sup>(1)</sup>
DIN	PN 10–40	40 bar <sup>(2)</sup>	40 bar <sup>(2)</sup>
DIN	PN 10/16	16 bar <sup>(2)</sup>	16 bar <sup>(2)</sup>
DIN	PN 25/40	40 bar <sup>(2)</sup>	40 bar <sup>(2)</sup>

(1) At 100 °F (38 °C); the rating decreases with increasing temperature.

(2) At 248 °F (120 °C); the rating decreases with increasing temperature.

## Burst Pressure All Models

10,000 psig (68.95 MPa) proof pressure on the flanges.

## Humidity Limits

0 to 100% relative humidity

## Volumetric Displacement

Less than 0.01 in<sup>3</sup> (0.16 cm<sup>3</sup>)

## Failure Mode Alarm (Output Code S)

If self-diagnosis detects a gross transmitter failure, the analog signal will be driven below 3.9 mA or above 21 mA to alert the user. High or low alarm signal is user selectable.

Level	4–20 mA Saturation Value	4–20 mA Alarm Value
Low	3.9 mA	3.75 mA
High	20.8 mA	21.75 mA

## Transmitter Security (Output Code S)

Activating the transmitter security function prevents changes to the transmitter configuration, including local zero and span adjustments. Security is activated by an internal switch.

## Overpressure Saturation Value (Output Code S)

If the sensor detects a negative overpressure value, the analog signal will be driven to 3.9 mA. If the sensor detects a positive overpressure value, the analog signal is driven to 20.8 mA.

## Damping

Numbers given are for silicone fill fluid at room temperature. The minimum time constant is 0.2 seconds (0.4 seconds for Range 3). Inert-filled sensor values would be slightly higher.

### Output Code S

Time constant is adjustable in 0.1 second increments from minimum to 16.0 seconds.

### Output Codes E and G

Time constant continuously adjustable between minimum and 1.67 seconds.

### Output Codes L, M

Damping is fixed at minimum time constant.

### 1151LT

Time constant continuously adjustable between 0.4 and 2.2 seconds with silicone oil fill, or 1.1 and 2.7 seconds with inert fill for flush models and electronics codes E or G.

## Turn-on Time

Maximum of 2.0 seconds with minimum damping. Low power output is within 0.2% of steady state value within 200 ms after application of power.

## Physical Specifications, Standard Configuration

### Electrical Connections

<sup>1</sup>/<sub>2</sub>–14 NPT conduit with screw terminals and integral test jacks compatible with miniature banana plugs (Pomona 2944, 3690, or equivalent). The HART Hand-Held Interface connections are fixed to the terminal block on smart transmitters.

### Wetted Materials

#### Isolating Diaphragms

316L SST, Hastelloy C-276, or Tantalum. See ordering table for availability per model type.

#### Drain/Vent Valves

316 SST or Hastelloy C-276, see ordering table for availability per model type.

#### Process Flanges and Adapters

Plated carbon steel, 316 SST or Hastelloy C-276, see ordering table for availability per model type.

#### Wetted O-rings

Viton® (other materials also available)

**Non-wetted Materials**

- Fill Fluid
  - Silicone oil or inert fill
- Nuts and Bolts
  - Plated carbon steel
- Blank flange (GP and AP only)
  - Plated carbon steel
- Electronics Housing
  - Low-copper aluminum. NEMA 4X
- Cover O-rings
  - Buna-N
- Paint
  - Polyurethane

**Process Connections**

**Rosemount 1151DP, HP, GP, AP**

1/4–18 NPT on 2.125-in. (54-mm) centers on flanges for Ranges 3, 4, and 5.

1/4–18 NPT on 2.188-in. (56-mm) centers on flanges for Ranges 6 and 7.

1/4–18 NPT on 2.250-in. (57-mm) centers on flanges for Range 8.

1/2–14 NPT on adapters.

For Ranges 3, 4, and 5, flange adapters can be rotated to give centers of 2.0 in. (51 mm), 2.125 in. (54 mm), or 2.250 in. (57 mm).

**Rosemount 1151LT**

High pressure side: 2-, 3-, or 4-in., Class 150, 300 or 600 flange; 50, 80, or 100 mm, PN 40 or 10/16 flange.

Low pressure side: 1/4–18 NPT on flange. 1/2–14 NPT on adapter.

**Weight**

12 lb (5.4 kg) for AP, DP, GP, and HP transmitters, excluding options. Meter option: Add 2 lb (1 kg)

TABLE 7. 1151LT Weight with Flange

Flange <sup>(1)</sup>	Flush lb. (kg)	2-in (50mm) Ext. lb. (kg)	4-in. (100mm) Ext. lb. (kg)	6-in. (150mm) Ext. lb. (kg)
2-in., Class 150	18 (8.2)	N/A	N/A	N/A
3-in., Class 150	23 (10.4)	25 (11.3)	26 (11.8)	27 (12.3)
4-in., Class 150	29 (13.2)	32 (14.5)	34 (15.4)	36 (16.3)
2-in., Class 300	20 (9.1)	N/A	N/A	N/A
3-in., Class 300	28 (12.7)	30 (13.6)	31 (14.1)	32 (14.5)
4-in., Class 300	38 (17.2)	41 (18.6)	43 (19.5)	45 (20.4)
2-in., Class 600	22 (10.0)	N/A	N/A	N/A
3-in., Class 600	31 (14.1)	33 (15.0)	34 (15.4)	35 (15.9)
DN 50, PN10-40	20 (9.1)	N/A	N/A	N/A
DN 80, PN 25/40	25 (11.3)	27 (12.3)	28 (12.7)	29 (13.2)
DN 100, PN 10/16	25 (11.3)	28 (12.7)	30 (13.6)	32 (14.5)
DN 100, PN 25/40	29 (13.2)	32 (14.5)	34 (15.4)	36 (16.3)

(1) Stainless steel flange weights are listed.

## Product Certifications

### Approved Manufacturing Locations

Rosemount Inc. — Chanhassen, Minnesota, USA  
Emerson Process Management GmbH & Co. — Wessling, Germany  
Emerson Process Management Asia Pacific Private Limited — Singapore  
Beijing Rosemount Far East Instrument Co., Limited – Beijing, China

### European Directive Information

The EC declaration of conformity for all applicable European directives for this product can be found on the Rosemount website at [www.rosemount.com](http://www.rosemount.com). A hard copy may be obtained by contacting our local sales office.

#### ATEX Directive (94/9/EC)

Emerson Process Management complies with the ATEX Directive.

#### European Pressure Equipment Directive (PED) (97/23/EC)

1151GP9, 0; 1151HP4, 5, 6, 7, 8 Pressure Transmitters  
— QS Certificate of Assessment - EC No. PED-H-100  
Module H Conformity Assessment

All other 1151 Pressure Transmitters  
— Sound Engineering Practice

Transmitter Attachments: Diaphragm Seal - Process Flange - Manifold  
— Sound Engineering Practice

#### Electro Magnetic Compatibility (EMC) (2004/108/EC)

All models  
— EN 61326: 1997 with Amendments A1, A2, and A3

### Hazardous Locations Certifications

#### North American Certifications

##### Ordinary Location Certification for Factory Mutual

As standard, the transmitter has been examined and tested to determine that the design meets basic electrical, mechanical, and fire protection requirements by FM, a nationally recognized testing laboratory (NRTL) as accredited by the Federal Occupational Safety and Health Administration (OSHA).

##### Factory Mutual (FM) Approvals

FM Explosion-Proof tag is standard. Appropriate tag will be substituted if optional certification is selected.



Explosion-Proof: Class I, Division 1, Groups B, C, and D.  
Dust-Ignition Proof: Class II, Division 1, Groups E, F, and G; Class III, Division 1. Indoor and outdoor use. NEMA 4X.  
Factory Sealed.

- 15 Intrinsically safe for Class I, II, and III Division 1, Groups A, B, C, D, E, F, and G hazardous locations in accordance with entity requirements and Control drawing 01151-0214 and 00268-0031. Non-incendive for Class I, Division 2, Groups A, B, C and D hazardous locations.  
For entity parameters see control drawing 01151-0214.

##### Canadian Standards Association (CSA) Approvals

- E6 Explosion-Proof for Class I, Division 1, Groups C and D; Class II, Division 1, Groups E, F, and G; Class III, Division 1 Hazardous Locations. Suitable for Class I, Division 2, Groups A, B, C, and D; CSA enclosure type 4X. Factory Sealed.
- I6 Intrinsically safe for Class I, Division 1, Groups A, B, C, and D hazardous locations when connected per Drawing 01151-2575. For entity parameters see control drawing 01151-2575. Temperature Code T2D.

### European Certifications

- I1 ATEX Intrinsically Safe and Combustible Dust (1151 Smart only)  
Certificate No.: BAS99ATEX1294X  
ATEX Marking  II 1 GD  
EEx ia IIC T5 (-60°C ≤ Ta ≤ 40°C)  
EEx ia IIC T4 (-60°C ≤ Ta ≤ 80°C)  
 1180  
IP66

#### TABLE 8. IS Entity Parameters

Ui = 30 V
Ii = 125 mA
Pi = 1.0 W (T4) or 0.67 W (T5)
Ci = 0.034 μF
Li = 20 μH

#### Special Conditions for Safe Use (X)

The apparatus, is not capable of withstanding the 500V test as required by EN 50020: 1994. This must be taken into account when installing the apparatus.

# Product Data Sheet

00813-0100-4360, Rev HA

March 2008

# Rosemount 1151

N1 ATEX Type n and Combustible Dust  
(1151 Smart only)  
Certificate No.: BAS 99ATEX3293X  
ATEX marking:  II 3 GD  
EEx nL IIC T5 (-40°C ≤ Ta ≤ 40°C)  
EEx nL IIC T4 (-40°C ≤ Ta ≤ 80°C)  
Dust Rating: T90 °C (Ta = -20°C to 40°C)  
Ui = 45 Vdc Max  
**CE**  
IP66

### Special Conditions for Safe Use (x)

The apparatus is not capable of withstanding the 500V insulation test required by EN 50021: 1999. This must be taken into account when installing the apparatus.

E8 ATEX Flame-Proof  
Certification Number CESI03ATEX037  
ATEX Marking  II 1/2 G  
EEx d IIC T6 (-40 ≤ Ta ≤ 40 °C)  
EEx d IIC T4 (-40 ≤ Ta ≤ 80 °C)  
**CE** 1180  
V = 60 Vdc maximum

## Australian Certifications

### Standards Association of Australia (SAA) Certification

E7 SAA Flame-proof  
Certificate Number Ex 494X  
Ex d IIB + H<sub>2</sub> T6  
DIP T6  
IP65  
**Special Conditions for safe use (x):**  
For transmitters having NPT, PG or G cable entry threads, an appropriate flame-proof thread adaptor shall be used to facilitate application of certified flame-proof cable glands or conduit system.

I7 SAA Intrinsically Safe  
Certificate Number: Ex 122X  
Ex ia IIC T5 (T<sub>amb</sub> = 40 °C)  
Ex ia IIC T4 (T<sub>amb</sub> = 60 °C)  
**Special Conditions for Safe Use (x):**  
The equipment has been assessed to the entity concept and accordingly the following electrical parameters must be taken into account during installation.

TABLE 9. Entity Parameters

Ui = 30V
Ii = 125 mA
Pi = 1.0 W (T4) or 0.67W (T5)
Ci = 14.8 nF
Li = 20 μH

N7 SAA Type n  
Certificate Number: Ex 887X  
Ex n IIC T6 (T<sub>amb</sub> = 40 °C)  
Ex n IIC T5 (T<sub>amb</sub> = 80 °C)  
IP66  
**Special Conditions for safe use (x):**  
The equipment must be connected to a supply voltage which does not exceed the rated voltage. The enclosure end caps must be correctly fitted whilst the equipment is energized.

## Combination Certifications

Stainless steel certification tag is provided when optional approval is specified. Once a device labeled with multiple approval types is installed, it should not be reinstalled using any other approval types. Permanently mark the approval label to distinguish it from unused approval types.

- C6 Combination of I6 and E6,
- K5 Combination of FM Approvals Explosion-Proof and I5.
- K6 Combination of E6, I6, I1, and E8

## Dimensional Drawings

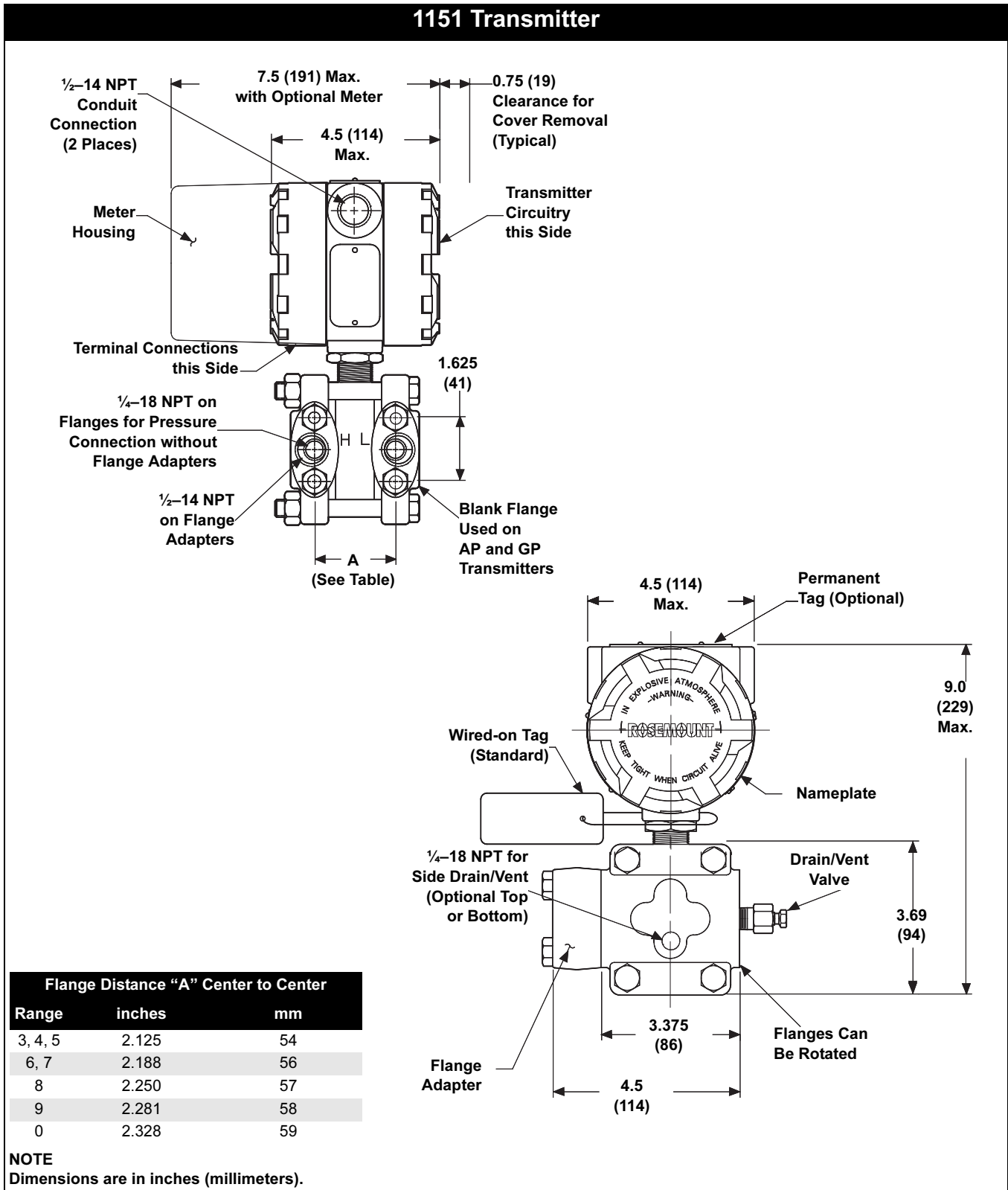

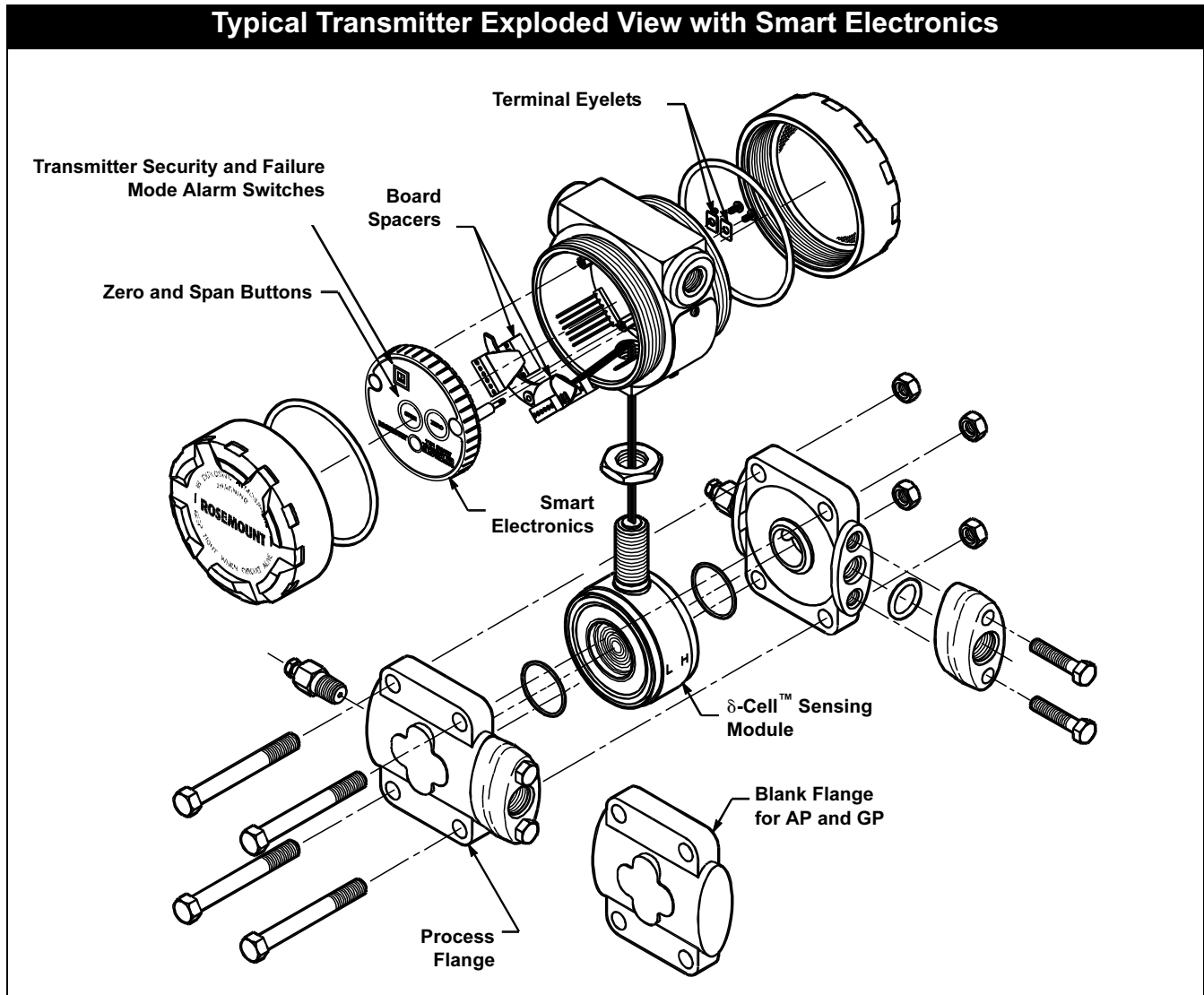

## 1151LT

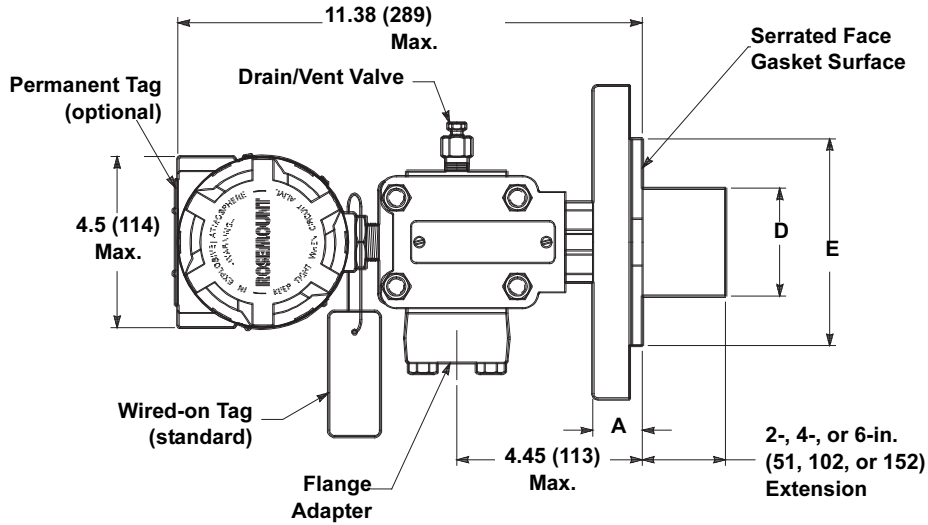

### OPTIONAL FLUSHING CONNECTION RING (LOWER HOUSING)

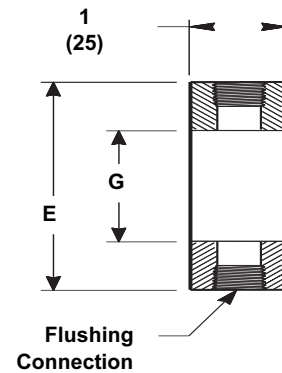

### DIAPHRAGM ASSEMBLY AND MOUNTING FLANGE

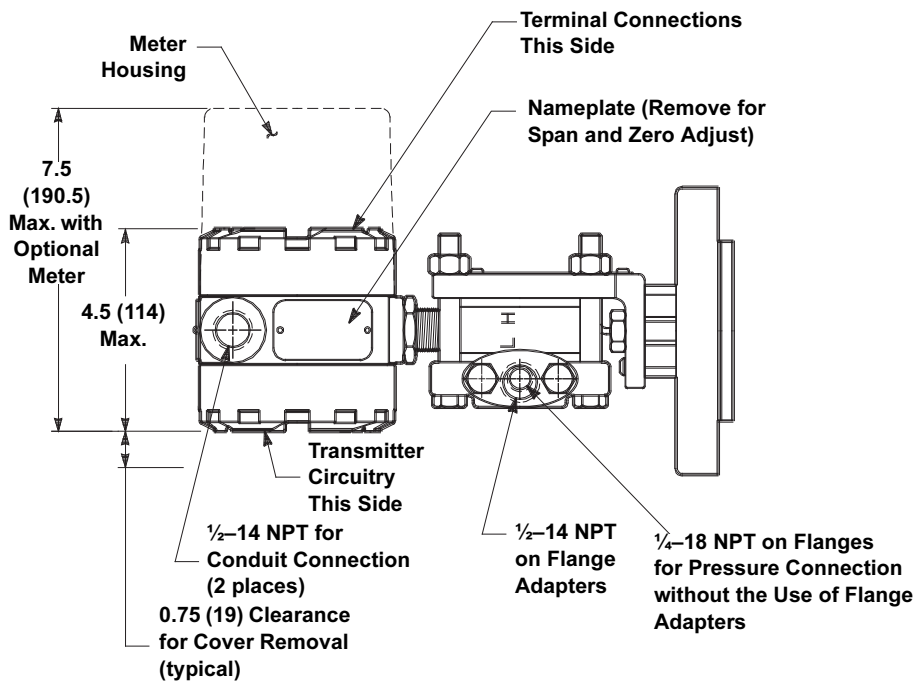
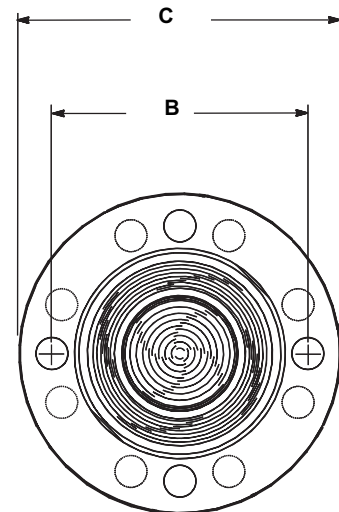

**NOTE**  
Dimensions are in inches (millimeters).

# Product Data Sheet

00813-0100-4360, Rev HA

March 2008

# Rosemount 1151

TABLE 10. 1151LT Dimensional Specifications

Class	Pipe Size	Flange Thickness A	Bolt Circle Diameter B	Outside Diameter C	No. of Bolts	Bolt Hole Diameter	Exten. Diam. D <sup>(1)</sup>	O.D. Gask. Surf. E	Proc. Side G
ANSI 150	2 (51)	1.12 (28)	4.75 (121)	6.0 (152)	4	0.75 (19)	NA	3.6(92)	2.12 (54)
	3 (76)	1.31 (33)	6.0 (152)	7.5 (191)	4	0.75 (19)	2.58 (66)	5.0 (127)	3.5 (89)
	4 (102)	1.31 (33)	7.5 (191)	9.0 (229)	8	0.75 (19)	3.5 (89)	6.2 (158)	4.5 (114)
ANSI 300	2 (51)	1.25 (32)	5.0 (127)	6.5 (165)	8	0.75 (19)	NA	3.6(92)	2.12 (54)
	3 (76)	1.50 (38)	6.62 (168)	8.25 (210)	8	0.88 (22)	2.58 (66)	5.0 (127)	3.5 (89)
	4 (102)	1.62 (41)	7.88 (200)	10.0 (254)	8	0.88 (22)	3.5 (89)	6.2 (158)	4.5 (114)
ANSI 600	2 (51)	1.12 (28)	5.0 (127)	6.5 (165)	8	0.75 (19)	NA	3.6(92)	2.12 (54)
	3 (76)	1.37 (35)	6.62 (168)	6.62 (168)	8	0.88 (22)	2.58 (66)	5.0 (127)	3.5 (89)
DIN PN10-40	DN 50	26 mm	125 mm	165 mm	4	18 mm	NA	4.0 (102)	2.5 (63)
DIN PN 25/40	DN 80	30 mm	160 mm	200 mm	8	18 mm	65 mm	5.4 (138)	3.7 (94)
DIN PN 10/16	DN 100	30 mm	190 mm	235 mm	8	22 mm	89 mm	6.2 (158)	4.5 (114)
DIN PN 10/16	DN 100	26 mm	180 mm	220 mm	8	18 mm	89 mm	6.2 (158)	4.5 (114)

(1) Tolerances are 0.040 (1.02), -0.020 (0.51).

## Mounting Bracket Option Codes B1, B4, and B7

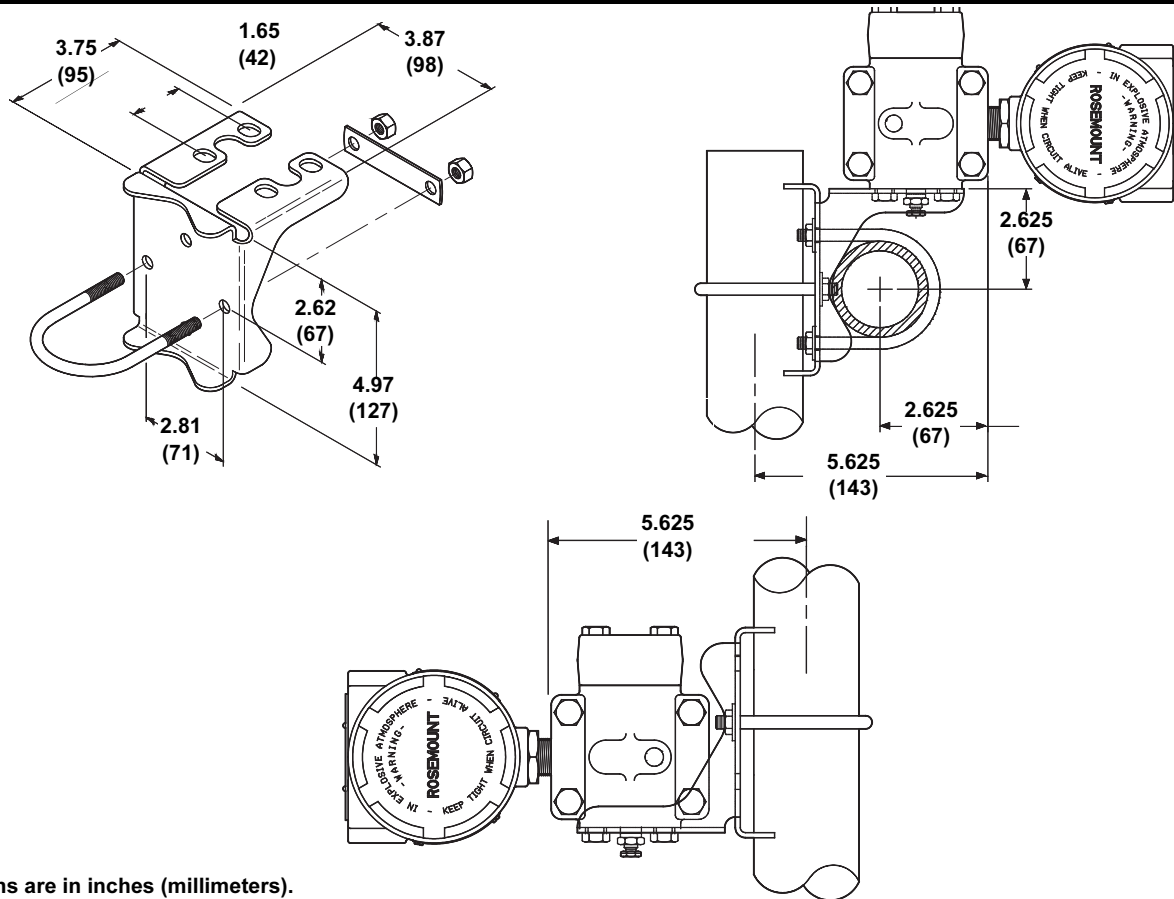

**NOTE**  
Dimensions are in inches (millimeters).

## Panel Mounting Bracket Option Codes B2 and B5

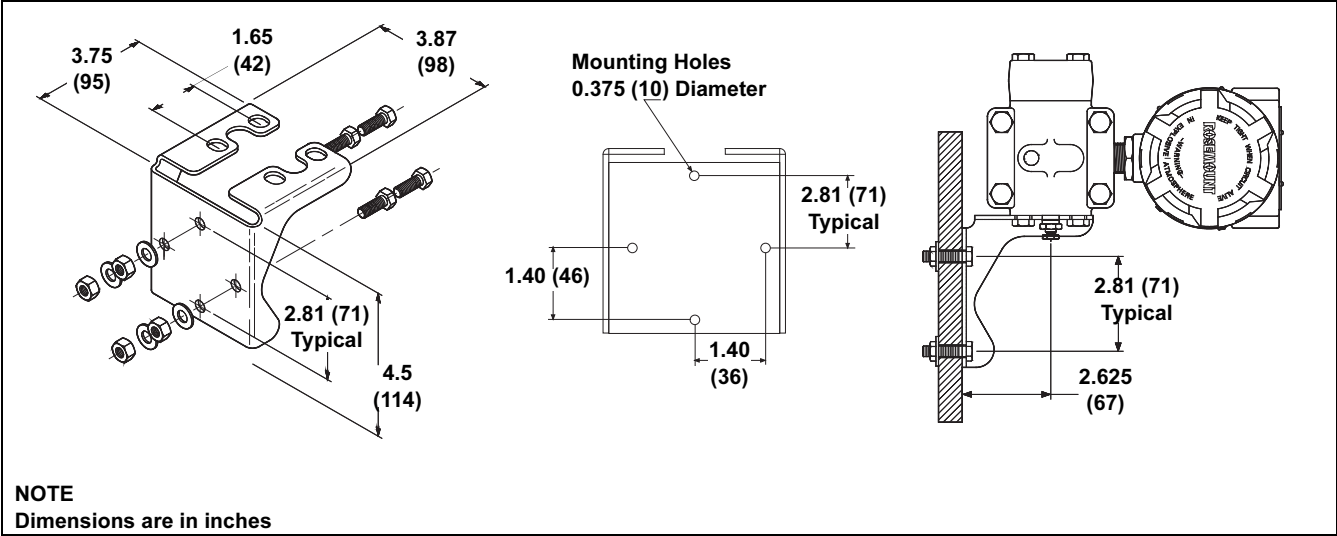

## Flat Mounting Bracket Option Codes B3, B6, and B9

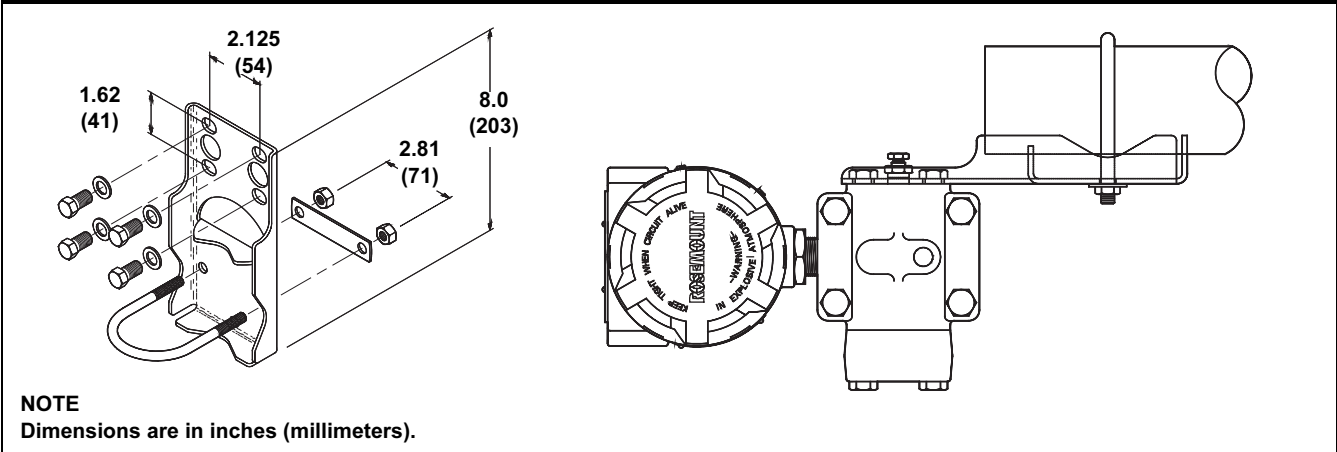

**Meter Options**

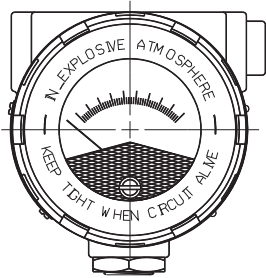

**OPTION CODE M1  
 LINEAR SCALE**

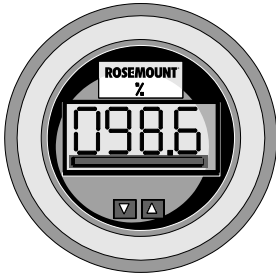

**OPTION CODE M4  
 LINEAR SCALE**

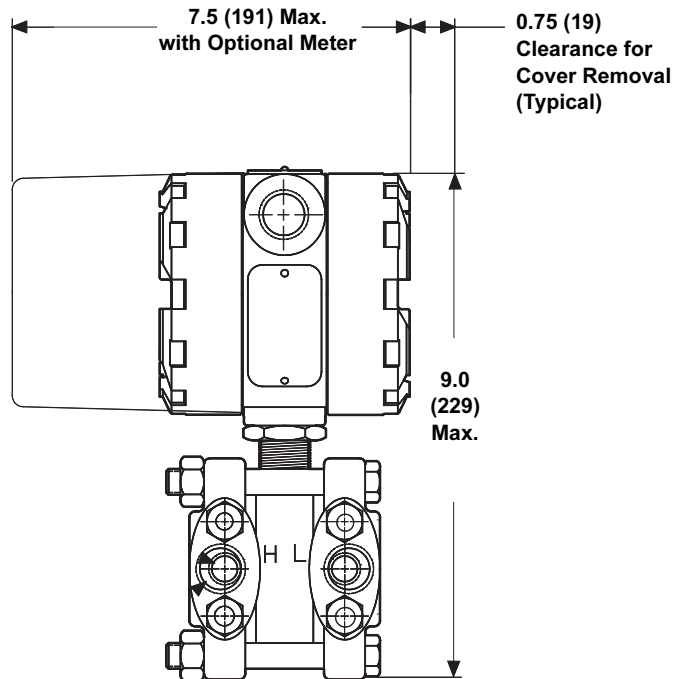

**NOTE**  
 Dimensions are in inches

**Flange Insert**

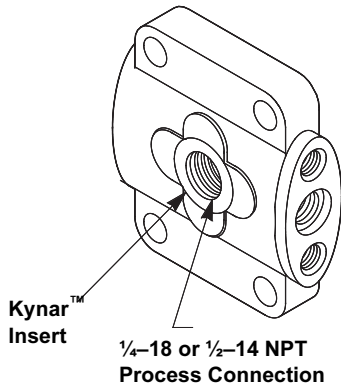

**1151 Process Connections**

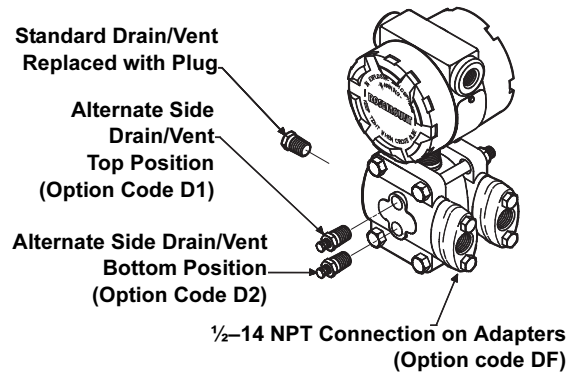

## Ordering Information

• = Applicable    — = Not Applicable

Model	Transmitter Type	DP	HP	GP	AP			
1151DP	Differential Pressure Transmitter	•	—	—	—			
1151HP	Differential Pressure Transmitter for High Line Pressures	—	•	—	—			
1151GP	Gage Pressure Transmitter	—	—	•	—			
1151AP	Absolute Pressure Transmitter	—	—	—	•			
Code	Pressure Ranges (URL) (select one)	DP	HP	GP	AP			
3	30 inH2O (7.46 kPa)	•	—	•	—			
4	150 inH2O (37.3 kPa)	•	•	•	•			
5	750 inH2O (186.4 kPa)	•	•	•	•			
6	100 psi (689.5 kPa)	•	•	•	•			
7	300 psi (2068 kPa)	•	•	•	•			
8	1,000 psi (6895 kPa)	•	—	•	•			
9	3,000 psi (20684 kPa)	—	—	•	—			
0	6,000 psi (41369 kPa)	—	—	•	—			
Code	Transmitter Output (select one)	DP	HP	GP	AP			
S	4–20 mA with Digital Signal based on HART Protocol (Smart)	•	•	•	•			
E	4–20 mA, Linear with Input	•	•	•	•			
G <sup>(1)</sup>	10–50 mA, Linear with Input	•	•	•	•			
L	Low Power 0.8 to 3.2 Vdc	•	•	•	•			
M <sup>(2)</sup>	Low Power 1 to 5 Vdc	•	•	•	•			
MATERIALS OF CONSTRUCTION <sup>(3)</sup>								
Code	Flanges/Adapters	Drains/Vents	Diaphragms	Fill Fluid	DP	HP	GP <sup>(4)</sup>	AP
52	Nickel-plated Carbon Steel	316 SST	316L SST	Silicone	•	•	•	•
53	Nickel-plated Carbon Steel	316 SST	Hastelloy C-276	Silicone	•	•	•	•
55	Nickel-plated Carbon Steel	316 SST	Tantalum	Silicone	•	—	•	—
22	316 SST	316 SST	316L SST	Silicone	•	•	•	•
23	316 SST	316 SST	Hastelloy C-276	Silicone	•	•	•	•
25	316 SST	316 SST	Tantalum	Silicone	•	—	•	—
33 <sup>(5)</sup>	Hastelloy C-276	Hastelloy C-276	Hastelloy C-276	Silicone	•	•	•	•
35	Hastelloy C-276	Hastelloy C-276	Tantalum	Silicone	•	—	•	—
73 <sup>(5)</sup>	316 SST	Hastelloy C-276	Hastelloy C-276	Silicone	•	•	•	•
83 <sup>(5)</sup>	Nickel-plated Carbon Steel	Hastelloy C-276	Hastelloy C-276	Silicone	•	•	•	•
5A	Nickel-plated Carbon Steel	316 SST	316L SST	Inert	•	—	•	—
5B	Nickel-plated Carbon Steel	316 SST	Hastelloy C-276	Inert	•	—	•	—
5D	Nickel-plated Carbon Steel	316 SST	Tantalum	Inert	•	—	•	—
2A	316 SST	316 SST	316L SST	Inert	•	—	•	—
2B	316 SST	316 SST	Hastelloy C-276	Inert	•	—	•	—
2D	316 SST	316 SST	Tantalum	Inert	•	—	•	—
3B	Hastelloy C-276	Hastelloy C-276	Hastelloy C-276	Inert	•	—	•	—
3D	Hastelloy C-276	Hastelloy C-276	Tantalum	Inert	•	—	•	—
7B <sup>(5)</sup>	316 SST	Hastelloy C-276	Hastelloy C-276	Inert	•	—	•	—
8B <sup>(5)</sup>	Nickel-plated Carbon Steel	Hastelloy C-276	Hastelloy C-276	Inert	•	—	•	—
Code	Mounting Brackets (optional - select one)	DP	HP	GP	AP			
B1	Bracket, 2-in. Pipe Mount	•	•	•	•			
B2	Bracket, Panel Mount	•	•	•	•			
B3	Bracket, Flat, 2-in. Pipe Mount	•	•	•	•			
B4	B1 Bracket w/Series 316 SST Bolts	•	•	•	•			
B5	B2 Bracket w/Series 316 SST Bolts	•	•	•	•			
B6	B3 Bracket w/Series 316 SST Bolts	•	•	•	•			
B7	316 SST B1 Bracket with 316 SST Bolts	•	•	•	•			
B9	316 SST B3 Bracket with 316 SST Bolts	•	•	•	•			

Code	Meters <sup>(6)</sup> (optional - select one)		DP	HP	GP	AP
M1	Analog Scale, Linear Meter, 0–100%		•	•	•	•
M2	Analog Scale, Square Root Meter, 0–100% Flow		•	•	—	—
M3 <sup>(7)</sup>	Analog Scale, Linear Meter, Special Scale		•	•	•	•
M4 <sup>(9)(8)</sup>	LCD Display, Linear Meter, 0–100%, User Selectable		•	•	•	•
M6	Analog Scale, Square Root Meter, 1–10√		•	•	—	—
M7 <sup>(9)</sup>	LCD Display, Linear Meter, Special Configuration		•	•	•	•
M8 <sup>(9)</sup>	LCD Display Square Root Meter, 0–100% Flow		•	•	—	—
M9 <sup>(9)</sup>	LCD Display, Square Root Meter, 0–10√		•	•	—	—
Code	Product Certifications		DP	HP	GP	AP
E8	ATEX Flameproof		•	•	•	•
I1 <sup>(10)</sup>	ATEX Intrinsic Safety	<b>NOTE</b> FM explosion-proof approval is standard.	•	•	•	•
N1 <sup>(10)</sup>	ATEX Type n		•	•	•	•
I5 <sup>(10)</sup>	FM Intrinsically Safe, Division 2		•	•	•	•
K5 <sup>(10)</sup>	FM Explosion-Proof, Dust Ignition-proof, Intrinsically Safe, Division 2		•	•	•	•
C6 <sup>(10)</sup>	CSA Explosion-Proof, Intrinsically Safe		•	•	•	•
I6 <sup>(10)</sup>	CSA Intrinsically Safe		•	•	•	•
K6 <sup>(10)</sup>	CSA Explosion-Proof, Dust Ignition-proof, Intrinsically Safe, Division 2		•	•	•	•
E6	CSA Explosion-Proof, Dust Ignition-proof, Division 2		•	•	•	•
E7	SAA Flameproof, Dust Ignition-proof		•	•	•	•
I7 <sup>(10)</sup>	SAA Intrinsic Safety		•	•	•	•
N7 <sup>(10)</sup>	SAA Type n		•	•	•	•
C5 <sup>(11)</sup>	Measurement Canada Accuracy Approval		•	•	•	•
Code	Housing (optional - select one)		DP	HP	GP	AP
H1 <sup>(12)</sup>	SST Non-wetted Parts on Transmitter without Meter		•	•	•	•
H2 <sup>(12)</sup>	SST Non-wetted Parts on Transmitter with Meter		•	•	•	•
H3	SST Housing, Covers, Conduit Plug, Lock-nut, without Meter		•	•	•	•
H4	SST Housing, Covers, Conduit Plug, Lock-nut, with Meter		•	•	•	•
C2 <sup>(13)</sup>	M20 Conduit Threads		•	•	•	•
J1	G½ Conduit Threads		•	•	•	•
Code	Terminal Blocks (optional - select one)		DP	HP	GP	AP
R1	Integral Transient Protection (Only available with Option Code S and E electronics)		•	•	•	•
Code	Bolts for Flanges and Adapters (optional - select one)		DP	HP	GP	AP
L3	ASTM A193-B7 Flange and Adapter Bolts		•	•	•	•
L4	316 SST Flange and Adapter Bolts		•	•	•	•
L5	ASTM A193-B7M Flange and Adapter Bolts		•	•	•	•
Code	Process Connections (optional <sup>(14)</sup> )	Materials	DP	HP	GP	AP
D1	Side Drain/ Vent, Top	316 SST	•	•	•	•
		Hastelloy C-276	•	•	•	•
D2	Side Drain/ Vent, Bottom	316 SST	•	•	•	•
		Hastelloy C-276	•	•	•	•
DF	½–14 NPT Flange adapter(s)- Material determined by flange material	Carbon Steel	•	•	•	•
		316 SST	•	•	•	•
		Hastelloy C-276	•	•	•	•
D4 <sup>(15)</sup>	Conformance to DIN EN61518 Ranges 3, 4, 5 with ¼ NPT Process Connections Thread (Available in Germany Only)		•	•	—	—
D5 <sup>(15)</sup>	Conformance to DIN EN61518 Ranges 6, 7, 8, without ¼ NPT Process Connections Thread (Available in Germany Only)		•	•	—	—
D6	316 SST Low Side Blank Flange		—	—	•	•
D9	JIS Process Connection–RC ¼ Flange with RC ½ Flange Adapter	Carbon Steel	•	•	•	•
		316 SST	•	•	•	•
		Hastelloy C-276	•	•	•	•
G1	DIN Spacing (Single Entry Port, No Side V/D Hole Flange)		•	•	•	•
G2	DIN Spacing (Single Entry Port, Two Side V/D Hole Flange)		•	•	•	•
G3	DIN Spacing (Dual Entry Port, No Side V/D Hole Flange)		•	•	•	•
G4	DIN Spacing (Dual Entry Port, One Top Side V/D Hole Flange)		•	•	•	•
G5	DIN Spacing (Dual Entry Port, One Bottom Side V/D Hole Flange)		•	•	•	•
G6	DIN Spacing (Dual Entry Port, Two Side V/D Hole Flange)		•	•	•	•

# Rosemount 1151

K1 <sup>(16)</sup>	Kynar insert, ¼–18 NPT	•	—	•	•
K2 <sup>(16)</sup>	Kynar insert, ½–14 NPT	•	—	•	•
S1 <sup>(17)(18)</sup>	Assemble to one Rosemount diaphragm seal	•	—	•	—
S2 <sup>(17)(18)</sup>	Assemble to two Rosemount diaphragm seals	•	—	—	—
S4 <sup>(18)(19)</sup>	Assemble to Rosemount 1195 Integral Orifice	•	—	—	—
S6 <sup>(18)</sup>	Assemble to Rosemount 304 Manifold or Connection System	•	•	•	•
<b>Code</b>	<b>Wetted O-ring Material (optional - select one)</b>	<b>DP</b>	<b>HP</b>	<b>GP</b>	<b>AP</b>
W2	Buna-N	•	•	•	•
W3	Ethylene-Propylene	•	•	•	•
W4	Aflas	•	•	•	•
W6 <sup>(20)(21)</sup>	Spring-loaded PTFE	•	—	•	•
W7 <sup>(21)(22)</sup>	PTFE	•	—	•	•
<b>Code</b>	<b>Special Configuration (Software)</b>	<b>DP</b>	<b>HP</b>	<b>GP</b>	<b>AP</b>
CN <sup>(23)(24)</sup>	Analog Output Levels Compliant with NAMUR Recommendation NE43: 27-June-1996 and Low Alarm Level	•	•	•	•
C4 <sup>(23)(24)</sup>	Analog Output Levels Compliant with NAMUR Recommendation NE43: 27-June-1996 and High Alarm Level	•	•	•	•
C9 <sup>(24)</sup>	Software Configuration (Requires completed Configuration Data Sheet)	•	•	•	•
<b>Code</b>	<b>Special Certifications</b>	<b>DP</b>	<b>HP</b>	<b>GP</b>	<b>AP</b>
Q4	Calibration Certificate	•	•	•	•
Q8 <sup>(25)</sup>	Material Traceability per EN 10204 3.1	•	•	•	•
Q16	Surface Finish Certification for Sanitary Remote Seals	•	•	•	•
<b>Code</b>	<b>Toolkit Total System Performance Reports</b>	<b>DP</b>	<b>HP</b>	<b>GP</b>	<b>AP</b>
QZ	Remote Seal System Performance Calculation Report	•	•	•	•
<b>Code</b>	<b>Procedures (optional - select one)</b>	<b>DP</b>	<b>HP</b>	<b>GP</b>	<b>AP</b>
P1 <sup>(26)</sup>	Hydrostatic Testing, 150% Maximum Working Pressure	•	•	•	•
P2 <sup>(27)</sup>	Cleaning for Special Service	•	•	•	•
P3	Cleaning for <1 PPM Chlorine/Fluorine	•	•	•	•
<b>Code</b>	<b>Outputs (optional - select one)</b>	<b>DP</b>	<b>HP</b>	<b>GP</b>	<b>AP</b>
V1 <sup>(28)</sup>	Reverse Output	—	—	•	—
V2 <sup>(29)</sup>	4–20 mV Test Signal	•	•	•	•
V3 <sup>(29)</sup>	20–100 mV Test Signal	•	•	•	•
<b>Typical Model Number: 1151DP 4 S 52 B3 M4</b>					

- (1) Output Code G is not available with CE Mark.
- (2) Meter or SST housing not valid with this option.
- (3) Bolts and conduit plugs are plated carbon steel.
- (4) On GP and AP transmitters, the low-side flange is plated carbon steel. For a stainless-steel low-side flange, order process connection Option Code D6.
- (5) These selections meet NACE material recommendations per MR 01-75.
- (6) Not available with Output Codes L or M, or Option Codes V2 or V3.
- (7) Limited availability. Contact your Emerson Process Management representative.
- (8) Specify the range, mode, and engineering units. Also, the 20 mA value must be greater than the 4 mA value.
- (9) Not available with Output Codes G.
- (10) Not available with Output Codes E, G, L, or M.
- (11) Limited availability depending on transmitter type and range. Contact an Emerson Process Management representative.
- (12) Option includes SST housing, covers, conduit plug, locknut, L4 bolting, and D6 low side blank flange for GP and AP transmitters. Option Codes L4 and D6 parts are included with housing Option Codes H1 and H2.
- (13) Not available with Output Codes L or M.
- (14) Allowable combinations are: D1, D3, D6; D2, D3, D6; and D6, S1.
- (15) Material Traceability Certificate Option Q8 available.
- (16) The maximum working pressure on this option is 300 psig. Available only with materials of construction Option Code 2x.
- (17) This option may only be used on Ranges 4–8.
- (18) "Assemble-to" items are specified separately and require a completed model number.
- (19) This option has a maximum static pressure rating of 3,000 psi, and is available for factory assembly only without associated piping and is available only for Ranges 2, 3, 4, and 5.
- (20) Contains a Hastelloy spring that is wetted by the process; consult factory for PTFE O-ring without a spring.
- (21) Available for all the ranges of DP (3-8), HP (4-7), and AP (4-8), but it is only available for GP ranges 3-8.
- (22) PTFE O-ring has seal property limitations; Consult an Emerson Process Management representative for more information.
- (23) NAMUR-Compliant operation is pre-set at the factory and cannot be changed to standard operation in the field.
- (24) Available with Output Code S only.
- (25) This option is available for the transmitter flange and adapters.
- (26) Hydrostatic testing for Range 0, 125% maximum working pressure.
- (27) Fluorolube® grease on wetted O-rings.
- (28) Reverse output option is not needed with smart electronics; configured via HART-based communicator.
- (29) Not available with Output Codes L or M.

Model	Product Description			
1151LT	Flange-Mounted Liquid Level Transmitter			
Code	Pressure Range			
4	150 inH <sub>2</sub> O (0–635 to 0–3,810 mmH <sub>2</sub> O)			
5	750 inH <sub>2</sub> O (0–3,175 to 0–19,050 mmH <sub>2</sub> O)			
6	2,770 inH <sub>2</sub> O (0–11.96 to 0–70.36 mmH <sub>2</sub> O)			
Code	Output			
S	4–20 mA with Digital Signal based on HART Protocol (Smart)			
E	4–20 mA, Linear with Input			
G <sup>(1)</sup> (2)	10–50 mA, Linear with Input			
Code	Size	Material	Extension Length	
G0	2 in./DN 50	316L SST	Flush Mount Only	When specifying these option codes, a lower housing must be selected from the flushing connection options.
H0	2 in./DN 50	Hastelloy C-276	Flush Mount Only	
J0	2 in./DN 50	Tantalum	Flush Mount Only	
A0	3 in./DN 80	316L SST	Flush Mount	
A2	3 in./DN 80	316L SST	2 in./50 mm	
A4	3 in./DN 80	316L SST	4 in./100 mm	
A6	3 in./DN 80	316L SST	6 in./150 mm	
B0	4 in./DN 100	316L SST	Flush Mount	<b>NOTE</b> Extension diameters are sized to fit Schedule 80 pipe. Consult factory for Schedule 40 pipe.
B2	4 in./DN 100	316L SST	2 in./50 mm	
B4	4 in./DN 100	316L SST	4 in./100 mm	
B6	4 in./DN 100	316L SST	6 in./150 mm	
C0	3 in./DN 80	Hastelloy C-276	Flush Mount	
C2	3 in./DN 80	Hastelloy C-276	2 in./50 mm	
C4	3 in./DN 80	Hastelloy C-276	4 in./100 mm	
C6	3 in./DN 80	Hastelloy C-276	6 in./150 mm	
D0	4 in./DN 100	Hastelloy C-276	Flush Mount	
D2	4 in./DN 100	Hastelloy C-276	2 in./50 mm	
D4	4 in./DN 100	Hastelloy C-276	4 in./100 mm	
D6	4 in./DN 100	Hastelloy C-276	6 in./150 mm	
E0	3 in./DN 80	Tantalum	Flush Mount Only	
F0	4 in./DN 100	Tantalum	Flush Mount Only	
MOUNTING FLANGE				
Code	Size	Rating	Material	Applicable with these High Pressure Side Diaphragm Sizes
M	2-in.	Class 150	CS	2 in./DN 50
A	3-in.	Class 150	CS	3 in./DN 80
B	4-in.	Class 150	CS	4 in./DN 100
N	2-in.	Class 300	CS	2 in./DN 50
C	3-in.	Class 300	CS	3 in./DN 80
D	4-in.	Class 300	CS	4 in./DN 100
P	2-in.	Class 600	CS	2 in./DN 50
E	3-in.	Class 600	CS	3 in./DN 80
X	2-in.	Class 150	SST	2 in./DN 50
F	3-in.	Class 150	SST	3 in./DN 80
G	4-in.	Class 150	SST	4 in./DN 100
Y	2-in.	Class 300	SST	2 in./DN 50
H	3-in.	Class 300	SST	3 in./DN 80
J	4-in.	Class 300	SST	4 in./DN 100
Z	2-in.	Class 600	SST	2 in./DN 50
L	3-in.	Class 600	SST	3 in./DN 80
Q	DN 50	PN 10-40	CS	2 in./DN 50
R	DN 80	PN 40	CS	3 in./DN 80
S	DN 100	PN 40	CS	4 in./DN 100
V	DN 100	PN 10/16	CS	4 in./DN 100
K	DN 50	PN 10-40	SST	2 in./DN 50

# Rosemount 1151

T	DN 80	PN 40	SST	3 in./DN 80
U	DN 100	PN 40	SST	4 in./DN 100
W	DN 100	PN 10/16	SST	4 in./DN 100

## SENSOR MODULE AND LOW-SIDE MATERIALS OF CONSTRUCTION

Code	Low-Side Flange and Adapter	Drain/ Vent Valves	Low-Side Isolator Diaphragm	Low-Side Fluid Fill
52	Nickel-plated CS	316 SST	316L SST	Silicone
55	Nickel-plated CS	316 SST	Tantalum	Silicone
22	316 SST	316 SST	316L SST	Silicone
23	316 SST	316 SST	Hastelloy C-276	Silicone
25	316 SST	316 SST	Tantalum	Silicone
33	Hastelloy C-276	Hastelloy C-276	Hastelloy C-276	Silicone
35	Hastelloy C-276	Hastelloy C-276	Tantalum	Silicone
5D	Nickel-plated CS	316 SST	Tantalum	Inert
2A	316 SST	316 SST	316L SST	Inert
2B	316 SST	316 SST	Hastelloy C-276	Inert
2D	316 SST	316 SST	Tantalum	Inert
3B	Hastelloy C-276	Hastelloy C-276	Hastelloy C-276	Inert
3D	Hastelloy C-276	Hastelloy C-276	Tantalum	Inert

Code	Process Fill - High Pressure Side	Temperature Limits
A	Syltherm XLT	-100 to 300 °F (-73 to 135 °C)
C	D. C. Silicone 704	60 to 400 °F (15 to 205 °C)
D	D. C. Silicone 200	-40 to 400 °F (-40 to 205 °C)
H	Inert	-50 to 350 °F (-45 to 177 °C)
G	Glycerin and Water	0 to 200 °F (-17 to 93 °C)
N	Neobee M-20	0 to 400 °F (-17 to 205 °C)
P	Propylene Glycol and Water	0 to 200 °F (-17 to 93 °C)

## Code Options

S1 <sup>(3)(4)</sup>	Assemble to one Rosemount diaphragm seal
<b>METERS</b>	
M1 <sup>(5)</sup>	Linear Meter, 0–100% Scale
M3 <sup>(5)</sup>	Special Scale Meter, Specify Range
M4 <sup>(5)(6)</sup>	LCD Display, 0–100%
M7 <sup>(5)(7)</sup>	LCD Display, Linear, Special Configuration
<b>TERMINAL BLOCKS</b>	
R1	Integral Transient Protection (Available with output codes S and E only)
<b>HARZARDOUS LOCATIONS CERTIFICATIONS</b>	
E8	ATEX Flameproof
I1 <sup>(8)</sup>	ATEX Intrinsic Safety
N1 <sup>(8)</sup>	ATEX Type n
I5 <sup>(8)</sup>	FM Intrinsically Safe, Division 2
K5 <sup>(8)</sup>	FM Explosion-Proof, Dust Ignition-proof, Intrinsically Safe, Division 2
C6 <sup>(8)</sup>	CSA Explosion-Proof, Intrinsically Safe
I6 <sup>(8)</sup>	CSA Intrinsically Safe
K6 <sup>(8)</sup>	CSA Explosion-Proof, Dust Ignition-proof, Intrinsically Safe, Division 2
E6	CSA Explosion-Proof, Dust Ignition-proof, Division 2
E7	SAA Flameproof, Dust Ignition-proof
I7 <sup>(8)</sup>	SAA Intrinsic Safety
N7 <sup>(8)</sup>	SAA Type n
C5 <sup>(9)</sup>	Measurement Canada Accuracy Approval

**NOTE**  
FM explosion-proof approval is standard.

# Product Data Sheet

00813-0100-4360, Rev HA

March 2008

# Rosemount 1151

### OTHER OPTIONS

W5	Copper O-ring for Vacuum Service (Nonwetted)
C2	M20 Conduit Threads
Q4	Calibration Data Sheet
Q8 <sup>(10)</sup>	Material Traceability per EN 10204 3.1B
Q16	Surface Finish Certification for Sanitary Remote Seals (all options)
QZ	Remote Seal System Performance Calculation Report
V1	Reverse Output
V2	4–20 mV Test Signal
V3	20–100 mV Test Signal
F_	Select One Code from Flushing Connections Lower Housing Option. See Table 11.

**Typical Model Number: 1151LT 4 S A0 A 52 D F1**

- (1) Not available with Output Codes E and G.
- (2) Output Code G is not available with CE Mark.
- (3) For welded capillary assemblies, order sensor module and low-side materials of construction Option Code 22 (refer to 00813-0100-4016 for more information).
- (4) "Assemble-to" items are specified separately and require a completed model number.
- (5) Not available with Option Codes Zx, V2, or V3.
- (6) Limited availability. Contact an Emerson Process Management representative.
- (7) Specify the Range, Mode, and Engineering Units. Also, the 20 mA value must be greater than the 4 mA value.
- (8) Not available with Output Codes E and G.
- (9) Limited availability depending on transmitter type and range. Contact an Emerson Process Management representative.
- (10) Available for the diaphragm, upper housing, flange, adapter, extension, and lower housing.

TABLE 11. Flushing Connections Lower Housing Options

• = Applicable — = Not Applicable

Code	Flushing Connection Ring Material (Lower Housing)	Flushing Connections	Size	Diaphragm Size		
				2-in.	3-in.	4-in.
F1	SST	1	1/4 - 18 NPT	•	•	•
F2	SST	2	1/4 - 18 NPT	•	•	•
F3 <sup>(1)</sup>	Hastelloy C-276	1	1/4 - 18 NPT	•	•	•
F4 <sup>(1)</sup>	Hastelloy C-276	2	1/4 - 18 NPT	•	•	•
F7	SST	1	1/2 - 14 NPT	•	•	•
F8	SST	2	1/2 - 14 NPT	•	•	•
F9	Hastelloy C-276	1	1/2 - 14 NPT	•	•	•
F0	Hastelloy C-276	2	1/2 - 14 NPT	•	•	•

(1) Not available with high pressure side Option Codes A0, B0, and G0.

## Standard Accessories

All models are shipped with drain/vent valves, and one instruction manual per shipment.

### Tagging

The transmitter will be tagged, at no charge, in accordance with customer requirements. All tags are stainless steel. The standard tag is wired to the transmitter, however a permanently attached tag is available upon request. Tag character height is 0.125 in. (0.318 cm).

### Calibration

Transmitters are factory calibrated to the customer's specified range. If calibration is not specified, the transmitters are calibrated at maximum range. Calibration is performed at ambient temperature and pressure.

## Options

The following sections describe a variety of available options for the 1151 Transmitter. These options permit greater application flexibility.

### Optional Manifolds

Refer to Manifold Product Data Sheet (document number 00813-0100-4839).

### Optional Diaphragm and Sanitary Seals

Refer to Product Data Sheet (document numbers 00813-0100-4016 or 00813-0201-4016)

### Mounting Brackets

#### B1 Bracket for 2-in. Pipe Mounting

- Bracket for mounting transmitter on 2-in. pipe
- Constructed of carbon steel with carbon steel U-bolt
- Coated with polyurethane paint

#### B4 Bracket for 2-in. Pipe with 316 SST Bolts

- Same bracket as Option Code B1 with 316 SST bolts

#### B7 304 SST Bracket and 316 SST Bolts for 2-in. Pipe Mounting

- Same bracket as Option Code B1 with all SST materials

#### B2 Bracket for Panel Mounting

- Bracket for mounting transmitter on panel or wall
- Constructed of carbon steel with carbon steel bolts
- Coated with polyurethane paint

#### B5 Bracket for Panel with 316 SST Bolts

- Same bracket as Option Code B2 with 316 SST bolts

#### B3 Flat Bracket for 2-in. Pipe Mounting

- Bracket for vertical mounting of transmitter on 2-in. pipe
- Constructed of carbon steel with carbon steel U-bolt
- Coated with polyurethane paint

### Process Connections

#### D1 Side Drain/Vent-Top

- Drain/vent valve mounted in side of flange.
- Top position used to vent gas buildup in liquid process applications with transmitter mounted vertically.

#### B6 Flat Bracket for 2-in. Pipe with 316 SST Bolts

- Same bracket as Option Code B3 with 316 SST bolts

#### B9 304 SST Flat Bracket and 316 SST Bolts for 2-in. Pipe Mounting

- Same bracket as Option Code B3 with all 316 SST materials

## Bolts and Nuts for Flanges and Adapters

Options permit bolts and nuts for flanges and adapters in the specified material.

- L3 ANSI/ASTM A - 193-B7
- L4 Austenitic 316 SST
- L5 ANSI/ASTM A193-B7M

## Meters

### Analog

- Meters have 2-in. (50.8 mm) scale
- Plug-in mounting configuration
- Indication accuracy  $\pm 2\%$
- Operating temperature limit:  $-40$  to  $150$  °F ( $-40$  to  $65$  °C)
- Meters are enclosed in a housing certified by Factory Mutual as Explosion-Proof for Class I, Division 1, Groups B, C, and D; Class II, Division 1, Groups E, F, and G and Class III, Division 1
- For optional CSA explosion-proof approval, see certification Option Code E6
- M1 Linear Analog Meter, 0–100% Scale
- M2 Square Root Analog Meter, 0–100% Flow Scale
- M3 Special Scaling Analog Meter (Specify Range)
- M6 Square Root Analog Meter, 0– $10^{\sqrt{\quad}}$  Scale

### LCD

- 4-digit display
- Indication accuracy  $\pm 0.25\%$  of calibrated span  $\pm 1$  digit
- Display resolution at  $\pm 0.5\%$  of calibrated span  $\pm 1$  digit
- Operating temperature limit:  $-4$  to  $158$  °F ( $-20$  to  $70$  °C)
- Plug-in mounting configuration
- Meters are enclosed in a housing certified by FM as Explosion-Proof for Class I, Division 1, Groups B, C, and D; Class II, Division 1, Groups E, F, and G and Class III, Division 1
- For Optional CSA explosion-proof approval, see certification Option Code E6
- Reverse output not available with LCD Display
- M4 Linear LCD Meter, 0 to 100%
- M7 Special Scale LCD Display (Specify Range, Mode, and Engineering Units)
- M8 Square Root LCD Display, 0 to 100%
- M9 Square Root LCD Display, 0– $10^{\sqrt{\quad}}$  Scale

## NOTES

Meter Options are not available with Output Codes L or M, or Option Codes V2 or V3. Meter Options M4, M7, M8, and M9 are not available with Output Code G.

- Plug of same material as requested flange inserted in end of flange opposite adapter.

# Product Data Sheet

00813-0100-4360, Rev HA

March 2008

# Rosemount 1151

## D2 Side Drain/Vent-Bottom

- Drain/vent valve mounted in side of flange.
- Bottom position used to drain liquid buildup in gas process applications with transmitter mounted vertically.
- Plug of same material as requested flange inserted in end of flange opposite adapter.

## D6 316 SST Low Side Flange (1151GP and 1151AP Only)

### DF 1/2-14 NPT flange adapters

- Options provide 1/2-14 NPT process connection on flanges rather than 1/4-18 NPT

### K1 1/4-18 NPT Kynar™ Process Flange Insert

### K2 1/2-14 NPT Kynar Process Flange Insert

- Options provide Kynar plastic process flange insert that prevents process from coming in contact with the metal of the flange. One process insert for the 1151GP and LT; two inserts for the 1151DP.
- Process connections are from the side.
- Available with carbon steel and stainless steel process flanges only.
- Pressure Maximum: 200 psi at 200 °F with Kynar impulse piping; 300 psi at 200 °F with metal impulse piping.

## S1 Assembled with One Remote Diaphragm Seal

## S2 Assembled with Two Remote Diaphragm Seals

- Options provide for the assembly of one or two remote diaphragm seals.

## S4 Assembled with 1195 Integral Orifice

- Designed for highly accurate, small-bore flow measurement of any clean gas, liquid, or vapor.
- Reduce the costs associated with traditional orifice plate installations.
- Several configurations are available factory assembled to Rosemount differential pressure transmitters.<sup>(1)</sup>
- Wide orifice bore/flow range capability.
- Wide choice of process connections, including threaded, socket weld, and ANSI flanges.
- Static pressure maximum limit is 3,000 psig.
- Wetted materials are available that comply with NACE MR 01-75(90).
- Available only with Ranges 2, 3, 4, and 5.

(1) Applicable only to orifice assemblies without piping.

## Wetted O-rings

- Standard: Viton®
- W2 Buna N
- W3 Ethylene-Propylene
- W4 Aflas®
- W5 Copper O-ring for Vacuum Service (Nonwetted - 1151LT only)
- W6 Spring-Loaded PTFE
  - Contains a Hastelloy spring that is in contact with the process fluid. Consult factory if Hastelloy is unacceptable.
- W7 PTFE

## Procedures

### Standard Configuration

Unless otherwise specified, transmitter will be shipped as follows:

Engineering Units:	inH <sub>2</sub> O
4 mA:	0
20 mA:	Upper Range Limit
Output:	Linear
Software Tag:	Blank

Customer may specify the above items at no charge. Software tag (8 characters) is left blank unless specified.

### C9 Custom Configuration (Option Code C9)

If Option Code C9 is ordered, the customer may specify the following data in addition to the standard configuration parameters.

Descriptor:	16 characters
Message:	32 characters
Date:	Day, Month, Year
Damping:	Seconds
Burst Mode:	Select Output Choice
Failure Mode:	High or Low
Transmitter Security:	Off or On

# Rosemount 1151

TABLE 12. Hydrostatic Test Pressure

Model	Test Pressure
1151DP	3,000 psi
1151HP	6,750 psi
1151AP	2,000 psi
1151GP	
Ranges 3–8	2,000 psi
Range 9	4,500 psi
Range 0	7,500 psi
1151LT	
Class 150 Flange	450 psi
Class 300 Flange	1,100 psi

## P1 Hydrostatic Testing

- Each transmitter is hydrostatic tested according to Table 12.
- Test medium is water.
- This option provided for transmitters with remote diaphragm seal on application only.
- Rosemount Procedure 1746 outlines the testing procedure.

## P2 Cleaning for Special Service

- This option minimizes contaminants to the process system by cleaning wetted surfaces with a suitable detergent.
- Rosemount Procedure 97412 outlines the cleaning procedure.

## P3 Cleaning for <1 PPM Chlorine/Fluorine

## Outputs

### V1 Reverse Output

- This option permits reversing of pressure input so that electrical output will increase as pressure input decreases.
- This option applies only to 1151GP and 1151LT. When this option is selected, the process flange, adapter, drain/vent valve, appropriate O-rings, and bolting are installed on low side of transmitter. Not available for Ranges 9 and 0.
- Not available with 1151AP. Reverse output on 1151DP and 1151HP can be obtained by connecting high-pressure input to low side of transmitter and vice versa.
- This option should not be ordered with smart transmitters (Output Code S). The 1151 Smart transmitter can be configured for reverse output through a HART-Compatible Interface.

### V2 1 $\Omega$ Test Resistor

- A 1  $\Omega$  precision resistor is mounted across the test terminals to provide 4–20 mV output or a 10–50 mV output if 10–50 mA output is used.
- This option cannot be used with any meter options or Option Codes I5 or I6.

### V3 5 $\Omega$ Test Resistor

- A 5  $\Omega$  precision resistor is mounted across test terminals to provide 20–100 mV output or a 50–250 mV output if 10–50 mA output is used.
- This option cannot be used with any meter options or Option Codes I5 or I6.



Standard Terms and Conditions of Sale can be found at [www.rosemount.com/terms\\_of\\_sale](http://www.rosemount.com/terms_of_sale)  
The Emerson logo is a trademark and service mark of Emerson Electric Co.  
Rosemount, Annubar, ProPlate, and the Rosemount logotype are registered trademarks of Rosemount Inc.  
HART is a registered trademark of the HART Communication Foundation.  $\delta$ -Cell is a trademark of Rosemount Inc.  
Fluorolube is a registered trademark of Hooker Chemical Co.  
Viton is a registered trademark of E.I. du Pont de Nemours & Co.  
Neobee M-20 is a registered trademark of Stepan Chemical Co.  
Syltherm and D.C. are registered trademarks of Dow Corning Corp.  
Atlas is a registered trademark of Asahi Glass Co., Ltd.  
Kynar is a trademark of Pennwalt Inc..

## Emerson Process Management

### Rosemount Inc.

8200 Market Boulevard  
Chanhassen, MN 55317 USA  
T (U.S.) 1 800 999 9307  
T (International) (952) 906 8888  
F (952) 949 7001

[www.rosemount.com](http://www.rosemount.com)

### Emerson Process Management Emerson Process Management Asia Pacific

Heath Place  
Bognor Regis  
West Sussex PO22 9SH  
England  
T 44 (0) 1243 863121  
F 44 (0) 1243 867554

**Private Limited**  
1 Pandan Crescent  
Singapore 128461  
T (65) 6777 8211  
F (65) 6777 0947  
[Enquiries@AP.EmersonProcess.com](mailto:Enquiries@AP.EmersonProcess.com)

